

END DRIVE, BOTTOM RIGHT HAND (SHOWN)
 END DRIVE, BOTTOM LEFT HAND (OPPOSITE)

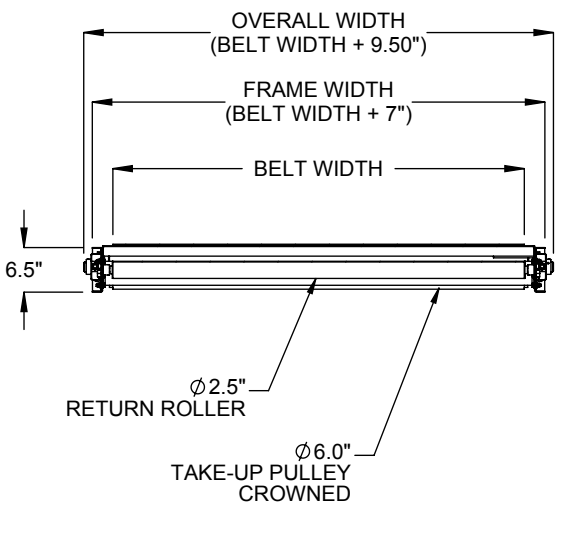

SECTION A-A
 TAKE-UP END
 TYP ALL DRIVES

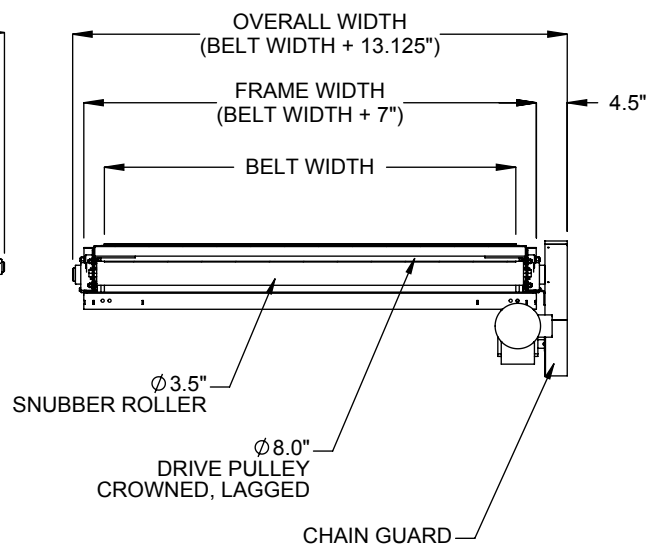

SECTION B-B
 DRIVE END

SPECIFICATIONS	
BELT WIDTH: 54", 60", 66", 72"	
BEGINNING ELEVATION: 9" - 126"	LENGTH: 60" - 1200"
ENDING ELEVATION: 9" - 126"	SPEED: 15 - 150 FPM
BELT: Standard is Trackmate 120 EMB embossed cover with clipper lace. Optional belts include Trackmate rough top, Trackmate friction cover, Trackmate longitudinal groove, food grade white PVC & plied rubber slip top. Other belt options available. V-belt construction is available.	
DRIVE: Standard drive is an end drive, bottom right hand. Optional drives include end drive, bottom left hand; Side drive right or left hand side; Center drive right or left hand side.	
MOTOR: 3/4 HP through 2 HP. Energy efficient, inverter duty & brake motors also available. Voltages include 120/1/60, 230/3/60, 460/3/60, 575/3/60 & DC Voltage	
SUPPORT CENTERS: Standard supports are floor supports on 10' centers. Optional floor supports on 5' centers; Ceiling supports on 5' & 10' centers.	
GUARDRAIL: <u>Optional</u> 2.5", 4.0" & 6.0"; 8ga bolt on channel.	
FRAME FINISH: Standard finish is OSHA safety blue powder. <u>Optional</u> colors include green, beige, gray, orange, black and yellow.	

Model: MDCSW - Medium Duty Channel Slider Bed Wide Belt Conveyor

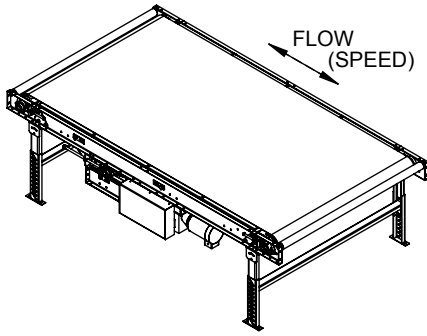

**CENTER DRIVE, RIGHT HAND (SHOWN)
CENTER DRIVE, LEFT HAND (OPPOSITE)**

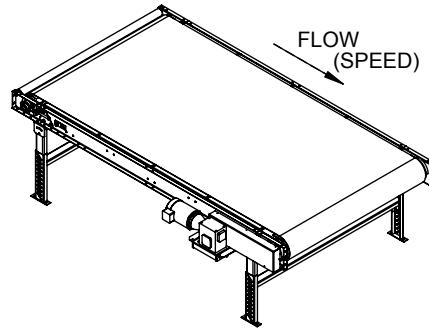

**SIDE DRIVE, RIGHT HAND (SHOWN)
SIDE DRIVE, LEFT HAND (OPPOSITE)**

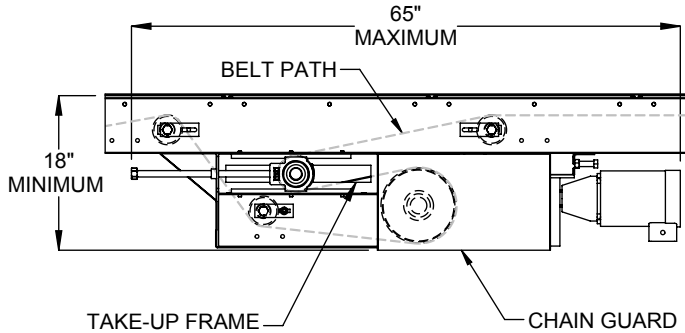

CENTER DRIVE OPTION

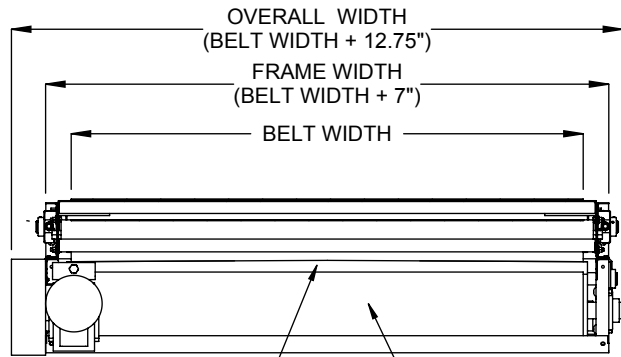

**CENTER DRIVE
END VIEW**

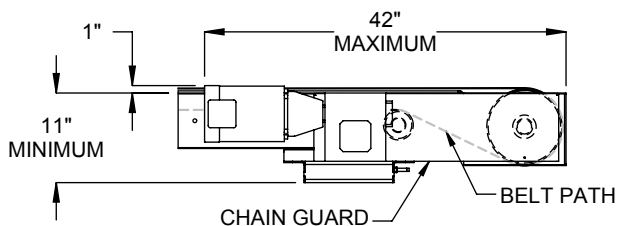

SIDE DRIVE OPTION

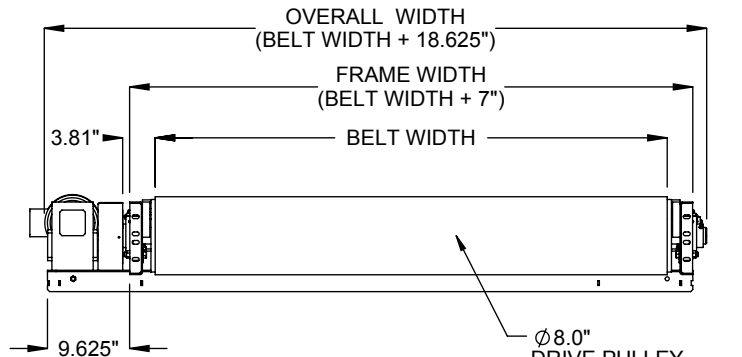

**SIDE DRIVE
END VIEW**

LOAD CAPACITY @ 60 FPM (LBS)

HP	WIDTH			
	54"	60"	66"	72"
1/2	245	240	235	225
3/4	400	395	385	380
1	550	545	540	530
1 1/2	860	850	845	840
2	1165	1155	1150	1145

LOAD CAPACITY @ 30 FPM (LBS)

HP	WIDTH			
	54"	60"	66"	72"
1/2	555	550	540	535
3/4	860	855	850	840
1	1165	1160	1155	1145
1 1/2	1780	1770	1765	1760
2	2390	2385	2380	2370

MAXIMUM LOAD PER LINEAR FOOT OF CONVEYOR IS 100 POUNDS - NOT TO EXCEED CAPACITY ABOVE

GUARD RAIL OPTION

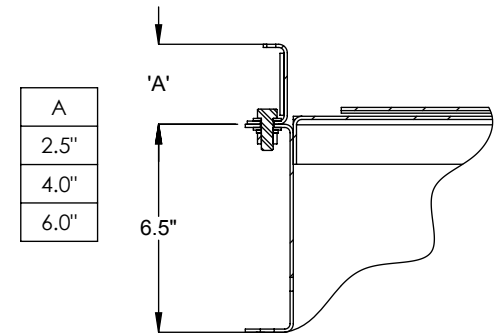

8ga BOLT ON CHANNEL

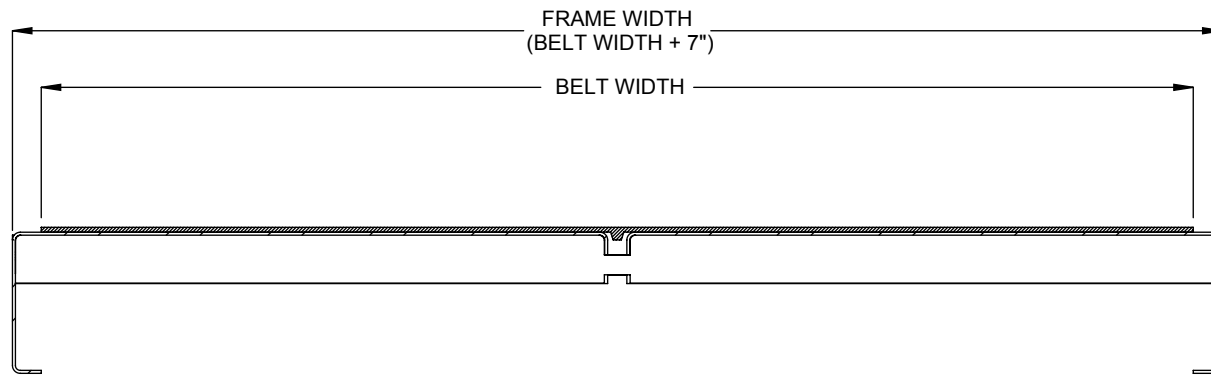

OPTIONAL V-BELT CONSTRUCTION

NOTE: PULLEYS ARE GROOVED TO ACCOMMODATE THE V-BELT