

END DRIVE, SIDE, RIGHT HAND (SHOWN)  
END DRIVE, SIDE, LEFT HAND (OPPOSITE)

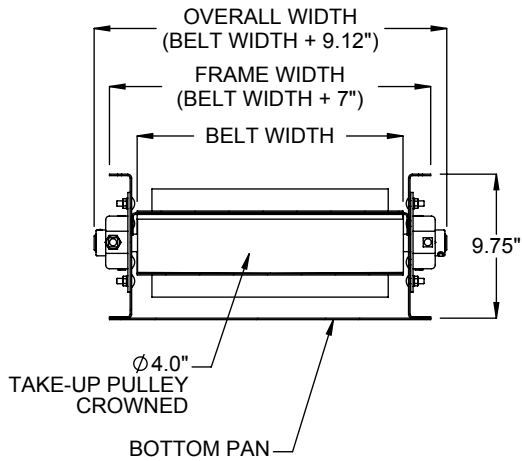

SECTION A-A  
TAKE-UP END  
TYPICAL ALL DRIVES

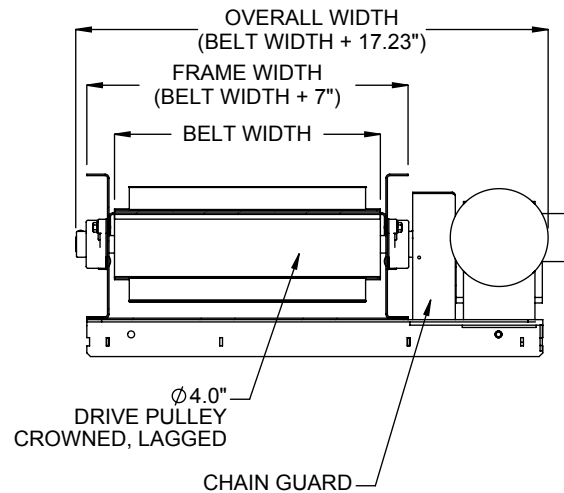

SECTION B-B  
DRIVE END

### SPECIFICATIONS

**BELT WIDTH:** 12", 18", 24", 30", 36"

**BEGINNING ELEVATION:** 8" - 126"

**LENGTH:** 60" - 240"

**ENDING ELEVATION:** 17" - 126"

**SPEED:** 15 - 150 FPM

**SUPPORT CENTER:** 0', 5', 10'

**INCLINED ANGLE:** 0 - 45°

**BELT:** Standard belt is PVC120 with 1-1/2" cleats on 12" centers. Optional belts include PVC120 with 1-1/2" cleats on 24" centers and white PVC food grade with 1-1/2" cleats on 12" or 24" centers.

**DRIVE:** Standard drive is an end drive, side, right hand. Optional drives include end drive, side, left hand; end drive and end drive top, right or left hand.

**MOTOR:** 1/2 HP through 1-1/2 HP. Energy efficient and inverter duty motors also available. Voltages include 120/1/60, 230/3/60, 460/3/60 and 575/3/60, , Brake, and DC Voltage.

**SUPPORT CENTERS:** Standard supports are floor supports on 10' centers. Optional on 5' centers.

**FRAME FINISH:** Standard finish is OSHA safety blue powder. Optional colors include green, beige, gray, orange, black and yellow.

**Model:** CMDSB - Cleated Medium Duty Slider Bed Belt Conveyor

REV

1



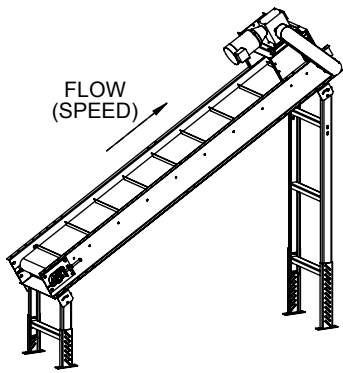

END DRIVE, TOP, RIGHT HAND (SHOWN)  
END DRIVE, TOP, LEFT HAND (OPPOSITE)

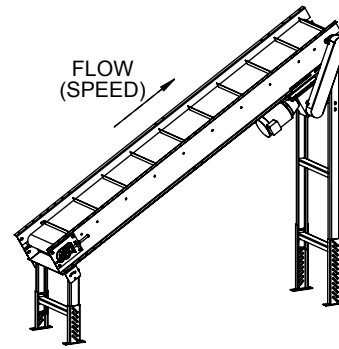

END DRIVE, BOTTOM, RIGHT HAND (SHOWN)  
END DRIVE, BOTTOM, LEFT HAND (OPPOSITE)

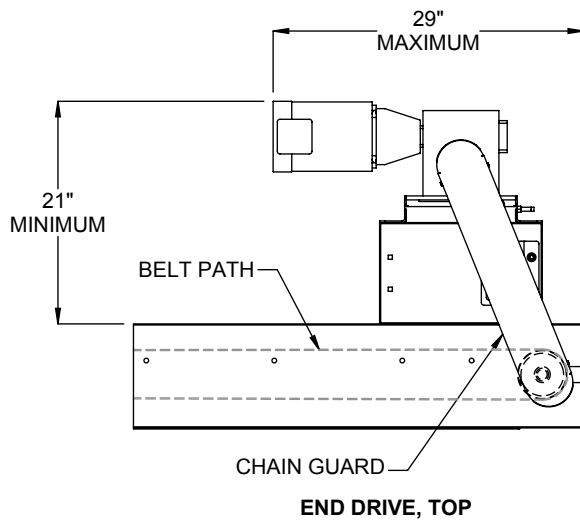

END DRIVE, TOP

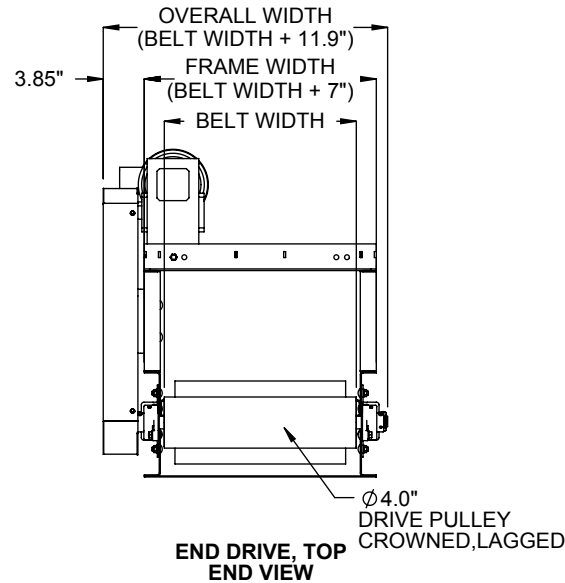

END DRIVE, TOP  
END VIEW

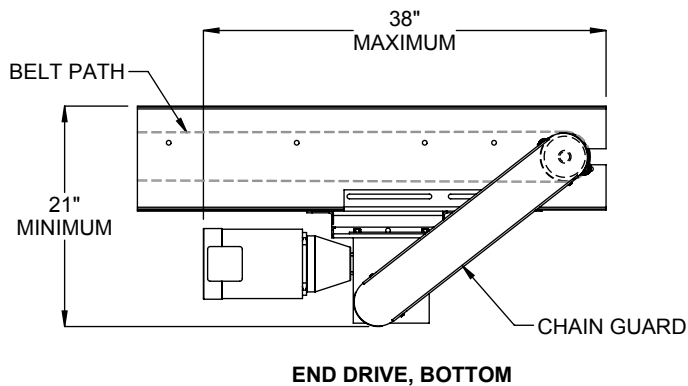

END DRIVE, BOTTOM

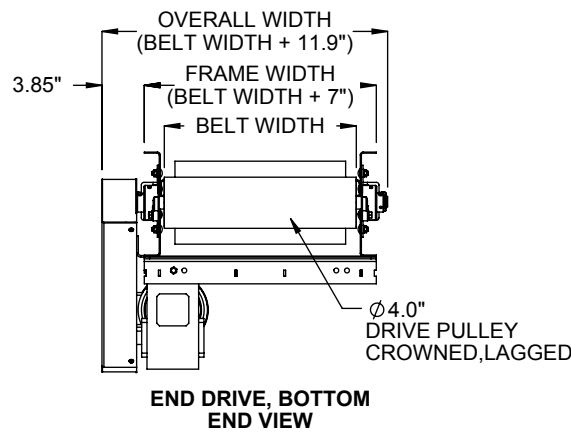

END DRIVE, BOTTOM  
END VIEW

**LOAD CAPACITY @ 60 FPM & 25° INCLINED ANGLE (LBS)**

HP	WIDTH				
	12"	18"	24"	30"	36"
1/2	160	155	150	145	140
3/4	240	235	230	225	220
1	320	315	310	305	300
1 1/2	485	480	475	470	465

**LOAD CAPACITY @ 30 FPM & 25° INCLINED ANGLE (LBS)**

HP	WIDTH				
	12"	18"	24"	30"	36"
1/2	325	320	315	310	305
3/4	485	480	475	470	465
1	650	645	640	635	630
1 1/2	-	970	965	960	955

**MAXIMUM LOAD PER LINEAR FOOT OF CONVEYOR IS 100 POUNDS - NOT TO EXCEED CAPACITY ABOVE**