

One of the world's highest quality ergonomic material handling equipment

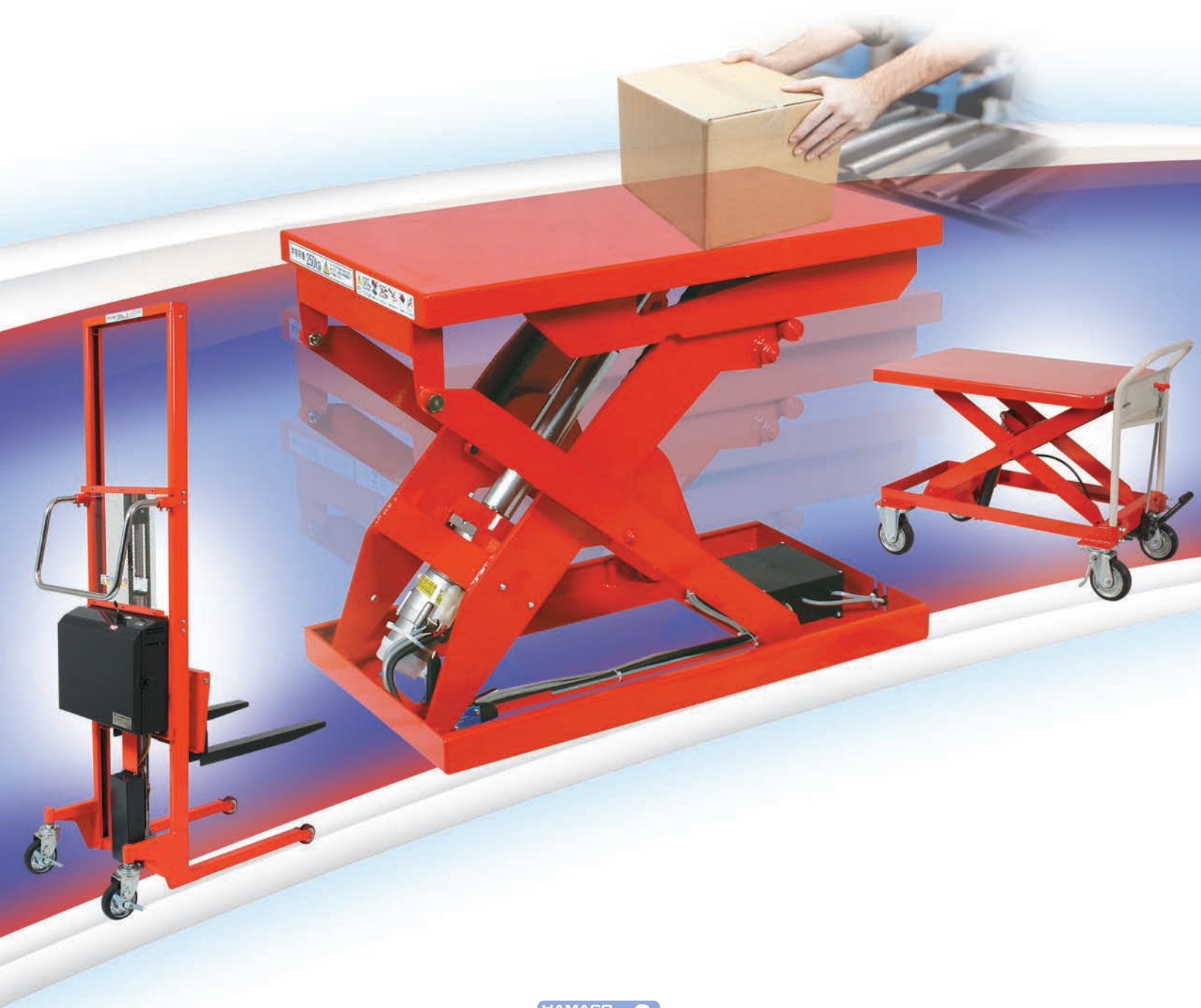

HAMACO Industries Corporation



Hamaco is proud to make one of the world's highest-quality lines of lifters. All of our products feature precision craftsmanship and are ergonomically designed, making them exceptionally easy to use and materials handling safer and more efficient.

Hamaco offers a wide range of models that assist in numerous functions throughout the manufacturing process, from the automation line and assembly to the casting foundry and everyday materials transportation. Some of our line includes:

- Hydraulic cylinder or dry cylinder designs
- Simultaneous control models
- Ultra-low floor models
- Mast-style models

All mechanical models feature ball screw lifting construction which eliminates oil leaks, prevents lift platforms from sinking during loading, and ensures consistent lift speeds for added ease and safety.

Useful at Every Stage of Production

Production

Flexible height adjustment and 360-degree rotating pedestal make it easy to adapt to your production line.

Machining and Inspection

Use as a convenient and sturdy tabletop that adjusts easily to your processes, from opening press holes to inspection.

Conveyor Line

Extend your conveyor line or loading area with one or more microcomputer-controlled lifters.

Loading & Unloading

Perfect for any warehouse environment, castors make it easy to move lifters with heavy loads quickly to any location.

Press and Process

When working with steel plates, processing machines, and other large items, combine the power of two or more lifters and a foot switch to accomplish your tasks efficiently and easily.

LIFT TABLES

Mechanical Lift (Ball Screw, Electric Type)

ML

Ultra-low Platform Mini Type

Compact, space-saving, and thin type which can be placed anywhere.

MAJOR FEATURES OF THE ML SERIES

- 3.1 in ultra-low platform (no external units)
- SPM motor
- Vector control
- Dry cylinder
- 110 V single-phase power supply
- Built-in unit
- Maximum starting frequency 10 times per minute
- Maximum usage frequency 30 times per hour
- Maximum/minimum limit switch
- Foot switch with LED Cord: 78.7 in
- Power cord: 118.1 in
- Bellows type full cover (with 'J' at the end)



ML-100-47V

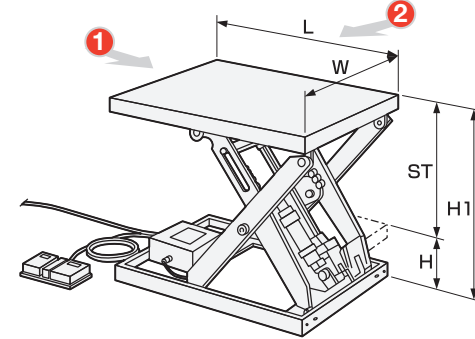
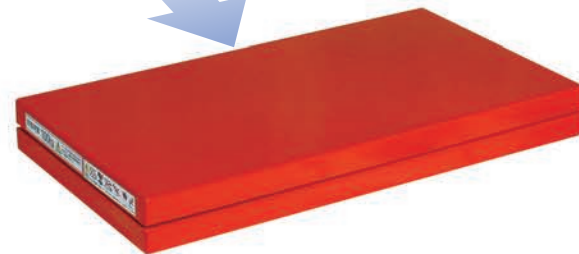

Load capacity: 220 / 330 lb

	Model	Load capacity	Table dimensions (W x L)	Stroke (ST)	Table height (H to H1)	Duration of lifting and lowering in seconds	Motor output Watts	Deadweight
Standard	ML-100-47V	220 lb	15.7" x 28.3"	19.6"	3.2" to 22.8"	10	70	79 lb
	ML-100-58V		20.5" x 33.5"					93 lb
	ML-150-45V	330 lb	15.7" x 19.7"	13.7"	3.2" to 16.9"			68 lb
	ML-150-56V		20.5" x 24.8"					77 lb
Bellows	ML-100-58VJ	220 lb	20.5" x 33.5"	19.6"	3.2" to 22.8"	10	70	104 lb
	ML-150-56VJ	330 lb	20.5" x 24.8"	13.7"	3.2" to 16.9"			86 lb

Unit: inch

* Bellows cannot be installed in a standard type.

Note After the lifter powers up, the lifter remembers the maximum and minimum position based on the first signals of the limit switch. On the succeeding operation, the lifter will stop at about 0.2 in lower than the maximum position during lifting and about 0.1 in higher than the minimum position when lowering.

Note When loading from the side of the table, please do so in the following manner: from side ① load less than or equal to 1/2 of the loading capacity (see table), and from side ② load less than or equal to 1/4 of the loading capacity (see table)

Note Do not carry out welding operations on top of the table.

Mechanical Lift (Ball Screw, Electric Type)

MLM

Mini Type

Compact, space-saving, and thin type which can be placed anywhere.

MAJOR FEATURES OF THE MLM SERIES

- 3.1 in ultra-low platform (no external units)
- SPM motor
- Vector control
- Dry cylinder
- 110 V single-phase power supply
- Built-in unit
- Maximum starting frequency 10 times per minute
- Maximum usage frequency 30 times per hour
- Maximum/minimum limit switch
- Foot switch with LED Cord: 78.7 in
- Power cord: 118.1 in
- Bellows type full cover (with 'J' at the end)



MLM-100-46WV-12

During Lowering

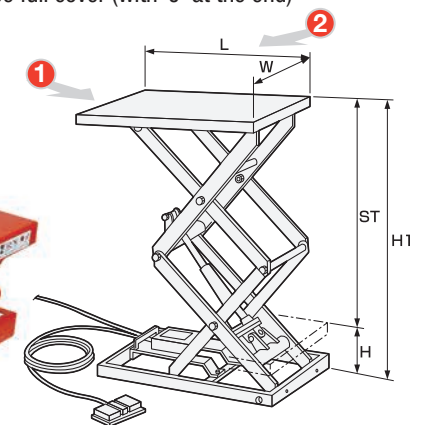

Load capacity: 220 / 551 lb

Unit: inch

	Model	Load capacity	Table dimensions (W x L)	Stroke (ST)	Table height (H to H1)	Duration of lifting and lowering in seconds	Motor output Watts	Deadweight				
Standard	MLM-100-46V-12	220 lb	15.7" x 25.6"	16.8"	5.2" to 22.0"	10	70	71 lb				
	MLM-100-56V-12		19.7" x 25.6"					75 lb				
	MLM-100-58V-12		20.5" x 33.5"					88 lb				
	MLM-250-47V-12	551 lb	15.7" x 28.3"	19.5"	6.0" to 25.5"			99 lb				
	MLM-250-58V-12		20.5" x 33.5"					110 lb				
	MLM-100-46WV-12		15.7" x 25.6"					93 lb				
Bellows	MLM-100-56WV-12	220 lb	19.7" x 25.6"	33.4"	7.9" to 41.3"	23	70	97 lb				
	MLM-100-58WV-12		20.5" x 33.5"					110 lb				
	MLM-100-58VJ-12	220 lb	20.5" x 33.5"					16.8"	5.2" to 22.0"	10	70	108 lb
	MLM-250-58VJ-12	551 lb	19.6"					6.0" to 25.6"	22	70	132 lb	
	MLM-100-58WVJ-12	220 lb	33.4"					7.9" to 41.3"	23	70	130 lb	

* Bellows cannot be installed in a standard type.

Note After the lifter powers up, the lifter remembers the maximum and minimum position based on the first signals of the limit switch. On the succeeding operation, the lifter will stop at about 0.2 in lower than the maximum position during lifting and about 0.1 in higher than the minimum position when lowering.

Note When loading from the side of the table, please do so in the following manner: from side ① load less than or equal to 1/2 of the loading capacity (see table), and from side ② load less than or equal to 1/4 of the loading capacity (see table).

Note Do not carry out welding operations on top of the table.

Mechanical Lift (Ball Screw, Electric Type)

MLSB

Ultra-low & Slim Type

It's possible to directly place a hand-pushed cart or a flat cart currently in use on top of the lift. Work can be more efficient since there is no need to pile up items over again on the table lift.

MAJOR FEATURES OF THE MLSB SERIES

- Ultra-low platform
- Stand-alone unit
- Foot switch cord: 78.7in.
- High-pressure hose: 78.7in.
- Power cord: 157.9in. (E-type)
- Maximum usage frequency: 30 times per hour



MLS-100-2007

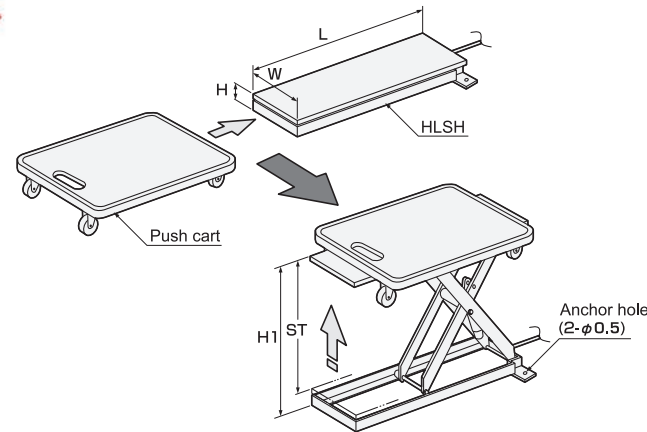

Load capacity: 220 lb

Unit: inch

	Model	Load capacity	Table dimensions (W x L)	Stroke (ST)	Table height (H to H1)	Lifting duration in seconds	Lowering duration in seconds	Output Watts	Deadweight		
Electric ball screw type	MLS-100-2007	220 lb	7.9" x 27.6"	19.6"	3.2" to 22.8"	12	12	70	62 lb		
	MLS-100-2507		9.8" x 27.6"						66 lb		
	MLS-100-3007		11.8" x 27.6"						71 lb		
	MLS-100-2009		7.9" x 35.4"	25.5"	3.2" to 28.7"				15	15	75 lb
	MLS-100-2509		9.8" x 35.4"								79 lb
	MLS-100-3009		11.8" x 35.4"								84 lb

* When the table is raised from the lowest position to the highest position, the table shifts up to 1.1in. in the longitudinal direction (direction of L).

Note After the lifter powers up, the lifter remembers the maximum and minimum position based on the first signals of the limit switch. On the succeeding operation, the lifter will stop at about 0.2in. lower than the maximum position during lifting and about 0.1in. higher than the minimum position when lowering.

Mechanical Lift (Ball Screw, Electric Type)

MLP

Mini Type Using IPM Motor

Long Service Life and High Output by Adopting the IPM Motor

MAJOR FEATURES OF THE MLP SERIES

- IPM motor
- Vector control
- Dry ball screw cylinder
- No oil leaks
- No hydraulic drift
- 110 V single-phase power supply
- Built-in unit
- Maximum starting frequency 10 times per minute
- Maximum/minimum limit switch
- Foot switch with LED Cord: 78.7 in
- Power cord: 118.1 in
- Enhanced rigidity with cam-type cylinder head
- Enhanced durability through strengthening the axis
- Bellows type full cover (with 'J' at the end)



MLP-250-47

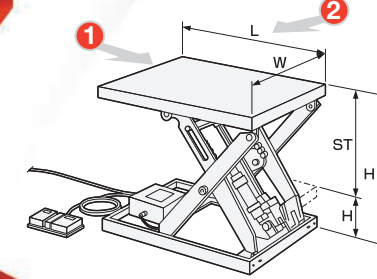

Load capacity: 551 / 1102 / 2204 lb

Unit: inch

	Model	Load capacity	Table dimensions (W x L)	Stroke (ST)	Table height (H to H1)	Lifting duration in seconds Unloaded to loaded	Lowering duration in seconds Unloaded to loaded	Usage frequency	Deadweight
Standard	MLP-250-47	551 lb	15.7" x 28.3"	16.2"	6.2" to 22.4"	Approx. 20	Approx. 20	15 times / hour	99 lb
	MLP-250-58		20.5" x 33.5"						110 lb
Bellows	MLP-250-58J	551 lb	20.5" x 33.5"	16.2"	6.2" to 22.4"	Approx. 20	Approx. 20	15 times / hour	132 lb
	MLP-250-69V-12	551 lb	23.6" x 35.4"	23.5"	4.0" to 27.5"	Approx. 14	Approx. 14	15 times / hour	220 lb
	MLP-250-610V-12		23.6" x 41.3"	28.2"	4.0" to 32.2"	Approx. 18	Approx. 18		254 lb
	MLP-250-89V-12		31.5" x 37.4"	23.5"	4.0" to 27.5"	Approx. 14	Approx. 14		232 lb
	MLP-250-810V-12		31.5" x 41.3"	28.2"	4.0" to 32.2"	Approx. 18	Approx. 18		276 lb
MLP-500-610V-12	23.6" x 41.3"		28.2"	5.4" to 33.6"	Approx. 14	Approx. 14	331 lb		
Standard	MLP-500-612V-12	1102 lb	25.6" x 47.2"	32.1"	5.4" to 37.5"	Approx. 15	Approx. 15	15 times / hour	353 lb
	MLP-500-810V-12		31.5" x 41.3"	28.2"	5.4" to 33.6"	Approx. 14	Approx. 14		353 lb
	MLP-500-812V-12	31.5" x 47.2"	32.1"	5.4" to 37.5"	Approx. 15	Approx. 15	375 lb		
	MLP-1000-610V-12	2204 lb	25.6" x 41.3"	22.7"	6.2" to 28.9"	Approx. 25	Approx. 25		331 lb
	MLP-1000-612V-12		25.6" x 47.2"	28.6"	6.2" to 34.8"	Approx. 32	Approx. 32		397 lb
	MLP-1000-810V-12		31.5" x 41.3"	22.7"	6.2" to 28.9"	Approx. 25	Approx. 25		342 lb
MLP-1000-812V-12	31.5" x 47.2"		28.6"	6.2" to 34.8"	Approx. 32	Approx. 32	408 lb		

* Bellows cannot be installed in a standard type.

Note After the lifter powers up, the lifter remembers the maximum and minimum position based on the first signals of the limit switch. On the succeeding operation, the lifter will stop at about 0.2 in lower than the maximum position during lifting and about 0.1 in higher than the minimum position when lowering.

Note When loading from the side of the table, please do so in the following manner: from side 1 load less than or equal to 1/2 of the loading capacity (see table), and from side 2 load less than or equal to 1/4 of the loading capacity (see table)

Note Few subductions will occur.

Note The unit cannot be used outdoors, or in places that are dusty, with high temperature and humidity, or in temperatures (0°C or below).

Mechanical Lift (Ball Screw, Electric Type)

MLP

Low & Mini Type
Using IPM Motor

Compact, space-saving, and thin type which can be placed anywhere.

MAJOR FEATURES OF THE MLP SERIES

- 3.3in. low platform (no external units)
- IPM motor
- Vector control
- Dry ball screw cylinder
- No oil leaks
- No hydraulic drift
- 110 V single-phase power supply
- Built-in unit
- Maximum starting frequency 10 times per minute
- Maximum/minimum limit switch
- Foot switch with LED Cord: 78.7in.
- Power cord: 118.1in.
- Enhanced rigidity with cam-type cylinder head
- Enhanced durability through strengthening the axis
- Bellows type full cover (with 'J' at the end)
- Quiet operation through the use of planetary gears in the decelerator (MLP-100-XX)
- With built-in control board BOX (excluding MLP-100-XX)



MLP-100-47

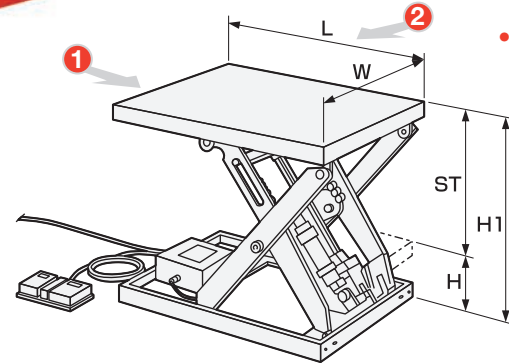

Load capacity: 220 / 330 lb

Unit: inch

	Model	Load capacity	Table dimensions (W x L)	Stroke (ST)	Table height (H to H1)	Lifting duration in seconds Unloaded to loaded	Lowering duration in seconds Unloaded to loaded	Usage frequency	Deadweight
Standard	MLP-100-47	220 lb	15.7" x 28.3"	19.4"	3.4" to 22.8"	Approx. 10	Approx. 10	30 times / hour	86 lb
	MLP-100-58		20.5" x 33.5"						93 lb
	MLP-150-45	330 lb	15.7" x 19.7"	13.5"	3.4" to 16.9"				68 lb
	MLP-150-56		20.5" x 24.8"						77 lb
Bellows	MLP-100-58J	220 lb	20.5" x 33.5"	19.4"	3.4" to 22.8"	Approx. 10	Approx. 10	30 times / hour	104 lb
	MLP-150-56J	330 lb	20.5" x 24.8"	13.5"	3.4" to 16.9"				86 lb

* Bellows cannot be installed in a standard type.

Note After the lifter powers up, the lifter remembers the maximum and minimum position based on the first signals of the limit switch. On the succeeding operation, the lifter will stop at about 0.2in. lower than the maximum position during lifting and about 0.1in. higher than the minimum position when lowering.

Note When loading from the side of the table, please do so in the following manner: from side ① load less than or equal to 1/2 of the loading capacity (see table), and from side ② load less than or equal to 1/4 of the loading capacity (see table)

Note Few subductions will occur.

Note The unit cannot be used outdoors, or in places that are dusty, with high temperature and humidity, or in temperatures (0°C or below).

Mechanical Lift Features

Hamaco lifts utilize a ball screw driving system, making them exceptionally compact and easily able to adapt to any work environment. This dry cylinder method, rather than hydraulics, virtually eliminates leaks and enhances performance. Additionally, they feature brushless motors for much greater longevity and simple maintenance.

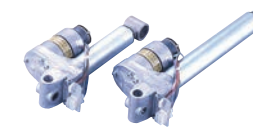

Parts of ball-screw



ball-screw



microcomputer control



Foot switch (with LED)

Some of the major advantages Hamaco lifts offer include:

Lower Cost

Costs less to purchase and maintain than hydraulic models.

No Leak

Using a dry cylinder, there's no oil leakage and the work environment stays clean.

Longer Life

With brushless motor design, it is not prone to typical wear and tear and will last significantly longer.

Precision Positioning

The ball-screw design makes it possible to perfectly position the lifts to your exact needs as well as to keep levels steady when loading or unloading the tables.

No Hydraulic Lift

Table height stays steady and consistent even when leaving it fully loaded for long periods of time.

Quiet

Hamaco motors are quiet during operation, eliminating additional workplace noise.

Easy Maintenance

Because of the simplified, clean design, such as long-life brushless motors and leak-free operation, maintenance is minimal and easy.

Built-in Power Unit

Lifters use a built-in power unit enabling you to use them anywhere

LED Alarm

A LED alarm on the foot switch alerts you to operational troubles.

High Quality Foot Switch

Made of durable, rigid plastic, the foot switch is two-toned (UP: black and DOWN: red) to make it easy to use even in low light. Switch is water-resistant.

Consistent Speed Control

By controlling the amount of current through the motor, we are able to accurately control the rotation speed. (mini type)

Ultra-Efficient

Because of significant efficiency advantages over hydraulic, the lifters are able to use smaller output motors to handle large loads.

Vector Control Features

While a conventional system (120-degree conduction system) has the current impressed in the motor as a square wave, a vector control impresses voltage, which turns into a sine wave toward the rotor's position (angle of the magnet), so it becomes possible to control the motor current.

Vector control offers numerous advantages, including:

- Efficient operation using low torque pulsation. By being able to control the motor current according to the angle of the magnet, you can achieve smoother acceleration and accurate stopping.
- It can instantly respond to speed changes during load fluctuations.
- Compared with conventional systems, the degree of speed regularity greatly improves when lifting or lowering, regardless of the load.

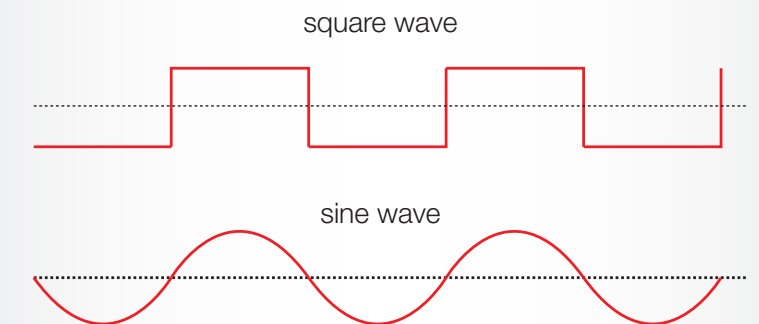

The IPM (Interior Permanent Magnet) Motor

A conventional SPM (Surface Permanent Magnet) motor features a permanent magnet attached to the rotor surface. It only uses magnetic torque from a magnet. On the other hand, the IPM (Interior Permanent Magnet) motor, like Hamaco uses, features an imbedded permanent magnet in the rotor itself and uses reluctance through magnetic resistance in addition to magnetic torque.

The IPM motor offers significant advantages:

High torque and high efficiency

By using reluctance torque in addition to magnetic torque, the motor can achieve high output.

Energy-saving operation

It consumes up to 30% less power compared to conventional SPM motors.

High-speed rotation

It can respond to high-speed motor rotation by controlling the two types of torque using vector control.

Safety

Since the permanent magnet is embedded, mechanical safety is improved. Unlike in a SPM, the magnet will not detach due to centrifugal force.

Example SPM/IPM Motor Rotor Structure

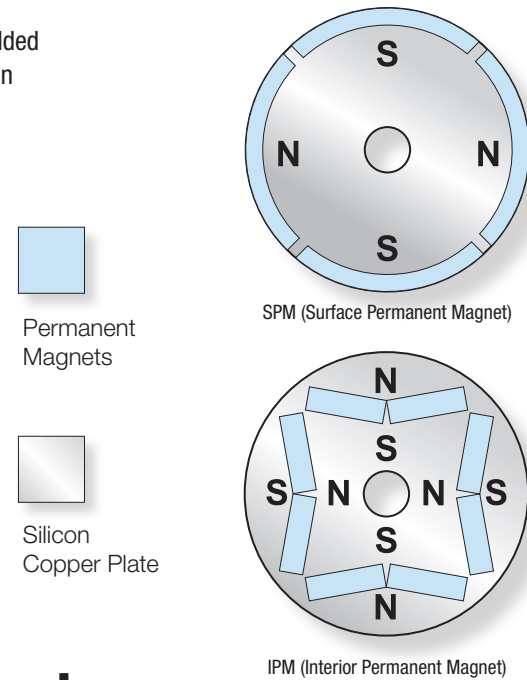

How the Brushless Motor Works

The Brushless Motor operates using a sensor and IC and without mechanical sliding parts such as brush and commutator. Because there is no friction, it lasts much longer and doesn't give off carbon. We use a microcomputer to control the lifter and it's possible to easily control and change functionality simply through software.

Controlling and Rotating the Motor

The brushless motor, like typical motors, uses a magnet to make it rotate. However, the brushless motor also relies on electrical current running through coils to move the rotor to the proper position, also called "repulsive force of attraction."

The right figure represents the rotation principle of the brushless motor (4-pole 6-coil). U, V, and W represent the coil, Hu, Hv, Hw indicates Hall element, and N, S is rotor magnetic pole. Also, (N), (S) shows the magnetic pole.

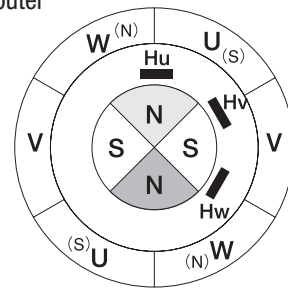

course	Hall element			coils		
	Hu	Hv	Hw	U	V	W
1	on	off	off	S		N
2	on	on	off		S	N
3	off	on	off	N	S	
4	off	on	on	N		S
5	off	off	on		N	S
6	on	off	on	S	N	

- ① Only Hu (Hall element) is ON. The rotor rotates to ② by making U → S and W → N.
- ② Hu and Hv are ON. The rotor rotates to ③ by making V → S and W → N.

Rotate the rotor using this control. Reverse N and S poles of the coil and it will spin in reverse.

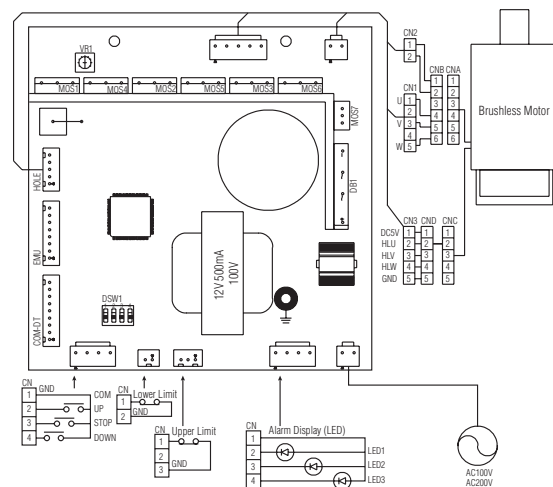

Brushless Mechanical Lifter Options

OPTION 1. Three Push Button

The three push button switches (rise, fall, and stop) work by holding Driving Mode. Push rise (fall) button one time and it operates automatically to the highest (lowest). The LED alarm display is lost, but the safeguard feature keeps working.

OPTION 2. Two Push Button

Using the two push button option (rise and fall), the LED alarm display is lost, but the safeguard feature keeps working.

HYDRAULIC LIFT TABLES

Hydraulic/Step Type

HLH

Standard

Free moving casters and wide stroke from a low position to a high position. The lowering of the table is minimized to 2% or less strokes when left for 15 minutes with the maximum load weight. (JIS standard)

MAJOR FEATURES OF THE HLH SERIES

- Hydraulic cylinder
- Swivel casters with brakes
- Foot pedal for easy height adjustment
- Overloading prevention device *1
- Springback mechanism in the release handle *2

Option

- Pump with a rapid traverse device

MAJOR SPECIFICATIONS

Oil Used

Turbine oil: ISO VG22

Materials

Pump : Urethane type resin spray painting

Cylinder : Urethane type resin spray painting

Main body : Baked melamine / Powder coating

- *1 The lifter will not elevate when overloaded.
 *2 In an emergency, lowering will stop as soon as you release the handle.
 To raise the lift, tighten the release handle.
 This is not attached to the HLH-120.



HLH-400M

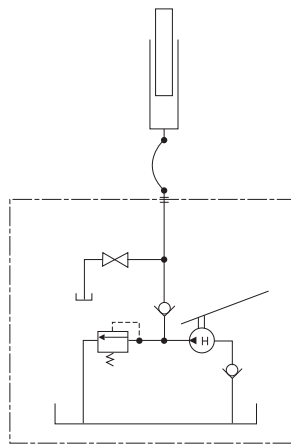

Hydraulic circuit diagram

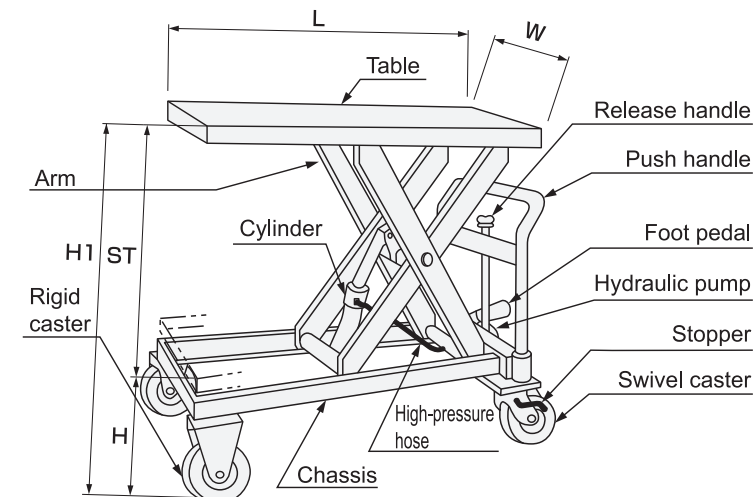

HLH-150



Foot pedal and Hydraulic pump



Hydraulic cylinder



HLH-400SW



HLH-400SW

Load capacity: 220 to 1543 lb

Unit: inch

	Model	Load capacity	Table dimensions (W x L)	Stroke (ST)	Table height (H to H1)	Overall Length (LL)	Wheels	Number of pedals Standard	Deadweight
Standard	HLH-100	220 lb	13.8" x 22.4"	15.7"	7.9" to 23.6"	30.1"	φ3.9 rubber	Approx. 12	41.9 lb
	HLH-120	264 lb	15.7" x 28.3"	19"	9.3" to 28.3"	36.6"	φ3.9 rubber	Approx. 20	66.1 lb
	HLH-150W	330 lb	19.7" x 31.5"	43.4"	14.0" to 57.4"	39.8"	φ3.9 rubber	Approx. 62	150 lb
	HLH-200	440 lb	19.7" x 31.5"	21.1"	10.3" to 31.4"	39.8"	φ3.9 rubber	Approx. 36	99 lb
	HLH-300W	661 lb	23.6" x 35.4"	47.9"	16.2" to 64.1"	44.1"	φ5.9 rubber	Approx. 85	220 lb
	HLH-400S	881 lb	19.7" x 31.5"	20.5"	10.9" to 31.4"	39.8"	φ3.9 urethane	Approx. 62	136.7 lb
	HLH-400SW		19.7" x 23.6"	27.3"	14.4" to 41.7"	32.1"	φ5.1 rubber	Approx. 58	154 lb
	HLH-400M		23.6" x 35.4"	23.6"	13" to 36.6"	44.1"	φ5.9 rubber	Approx. 58	176 lb
	HLH-400L		23.6" x 47.2"	34.2"	13" to 47.2"	55.9"	φ5.9 rubber	Approx. 85	220 lb
HLH-700	1543 lb	23.6" x 35.4"	23.6"	13" to 36.6"	44.1"	φ5.9 urethane	Approx. 85	176 lb	

* HLH-100's push handle can be folded.

Hydraulic/Step Type

HLH

Ultra-low Type



HLH-100-80L

During Lowering



Wide hoisting stroke. Equipped with wheels for easy movement. A lifter with many applications only limited by your imagination.

MAJOR FEATURES OF THE HLH SERIES

- Hydraulic cylinder
- Casters with brakes
- Foot pedal type
- Overloading prevention device
- Nose dive prevention valve (HLH-100-80L only)

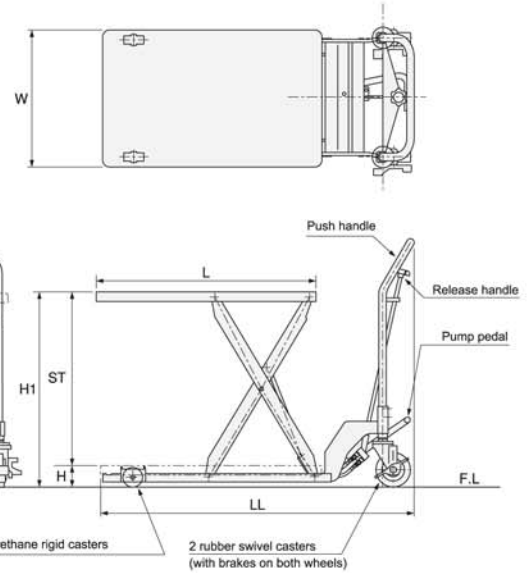

Load capacity: 220 / 440 lb

Unit: inch

	Model	Load capacity	Table dimensions (W x L)	Stroke (ST)	Table height (H to H1)	Total Length (LL)	Wheel Dimensions		Number of pump steps	Deadweight
							Rigid Caster	Swivel Casters with brakes		
Low	HLH-100-80L	220 lb	15.7"×28.3"	21.7"	3.2" to 24.9"	40.6"	φ3.0	φ3.9	Approx. 20	77 lb
Platform	HLH-200-80L	440 lb	19.7"×31.5"	24.8"	3.2" to 28.0"	44.9"	φ3.0	φ4.9	Approx. 46	125.7 lb

Note The swivel casters have rubber wheels and the rigid casters have urethane wheels.

Note HLH-100-80L has rubber wheels.